

Resistor Color Code

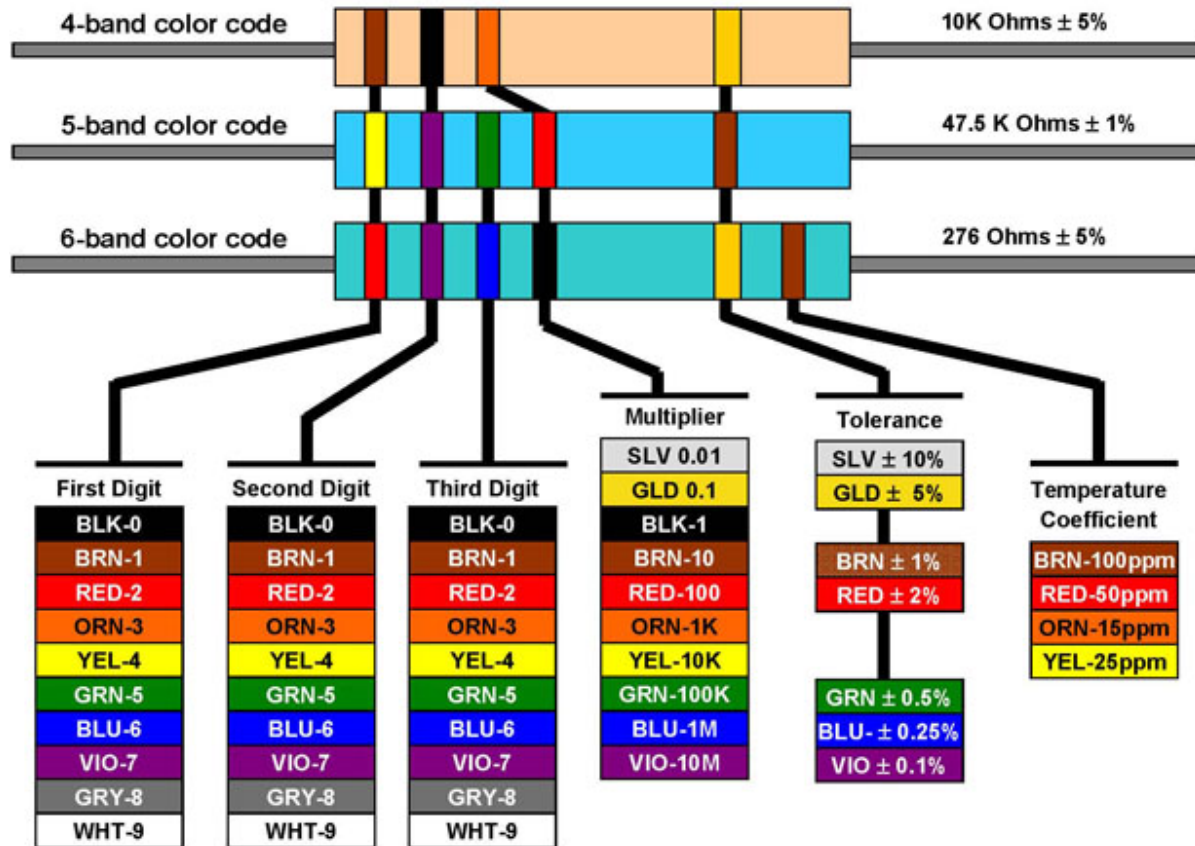

Resistor Color Codes: Resistors are devices that limit current flow and provide a voltage drop in electrical circuits. Because carbon resistors are physically small, they are color-coded to identify their resistance value in Ohms. The use of color bands on the body of a resistor is the most common system for indicating the value of a resistor. Color-coding is standardized by the Electronic Industries Association (EIA).

Use the Resistor Color Code Chart (above) to understand how to use the color code system. When looking at the chart, note the illustration of three round resistors with numerous color code bands. The first resistor in the chart (with 4 bands) tells you the minimum information you can learn from a resistor. The next (a 5-band code) provides a little more information about the resistor. The third resistor (a 6-band) provides even more information. Each color band is associated with a numerical value.

How to read a typical 4-band, 5-band and 6-band resistor: 4-Band: Reading the resistor from left to right, the first two color bands represent significant digits, the third band represents the decimal multiplier, and the fourth band represents the tolerance. 5-Band: The first three color bands represent significant digits, the fourth band represents the decimal multiplier, and the fifth band represents the tolerance. 6-Band: The first three color bands represent significant digits, the fourth band represents the decimal multiplier, the fifth band represents the tolerance, and the sixth band represents the temperature coefficient.

Definitions of color bands: The color of the multiplier band represents multiples of 10, or the placement of the decimal point. For example: ORANGE (3) represents 10 to the third power or 1,000. The tolerance indicates, in a percentage, how much a resistor can vary above or below its value. A gold band stands for +/- 5%, a silver band stands for +/- 10%, and if there is no fourth band it is assumed to be +/- 20%. For example: A 100-Ohm 5% resistor can vary from 95 to 105 Ohms and still be considered within the manufactured tolerance. The temperature coefficient band specifies the maximum change in resistance with change in temperature, measured in parts per million per degree Centigrade (ppm/°C).

Example (from chart): Let's look at the first resistor: on the chart. In this case, the first color band is BROWN. Following the line down the chart you can see that BROWN represents the number 1. This becomes our first significant digit. Next, look at the second band and you will see it is BLACK. Once again, follow the line down to the bar scale; it holds a value of 0, our second significant digit. Next, look at the third band, the multiplier, and you will see it is ORANGE. Once again, follow the line down to the bar scale; it holds a value of 3. This represents 3 multiples of 10 or 1000. With this information, the resistance is determined by taking the first two digits, 1 and 0 (10) and multiplying by 1,000. Example: $10 \times 1000 = 10,000$ or 10,000 Ohms. Using the chart, the fourth band (GOLD), indicates that this resistor has a tolerance of +/- 5%. Thus, the permissible range is: $10,000 \times .05 = +/- 500$ Ohms, or 9,500 to 10,500 Ohms.